

STRANDED COPPER CONDUCTOR ACCOMMODATED			BOLT SIZE	METRIC BOLT SIZE	COLOR CODE	DIE INFORMATION		MECHANICAL RATCHET						HYDRAULIC						DIELESS (# CRIMPS)	WIRE STRIP LENGTH	REV	DATE	DESCRIPTION	ECO	BY	C'H'K
CODE (AWG)	NAVY	METRIC SIZE (CLASS 2)				DIE INDEX	TYPE	Y1MRTC	OUR840	MD6 MD7	MD6-R2 MD7-34R	PATMD6 PAT600	Y34A Y34B Y34BH	Y35, Y39 Y750, PAT750	Y46 PAT46	Y45	Y48B	Y60BHU	A			11/7/2012	NEW SALES DRAWING CREATED	29234	SS	MA	
250 kcmil	250	120MM ² STR [14.5]	1/2	M12	YELLOW	16	YELLOW DIE SET	-----	X29RT (8)	W29VT (4)	W29RT (4) W29VT (4)	W29RT (4) W29VT (4)	A29R (2)	U29RT (2)	U29RT (2)	U29RT (2)	C29R(2)	L29RT(1)	MECHANICAL: MY29-3 (2), MY29 - 11(2) MRC - 840 (2) (4/0 ONLY)	1 - 11/16"							
							NEST	-----	-----	-----	-----	-----	B29D (2) A29D (2) Y34PR	U29D-1 (2) Y34PR	U29D-1 (2) Y34PR	U29D-1 (2) Y34PR	C29D(1) Y48PR	-----	HYDRAULIC: Y644 (1) PAT644 (1) Y81KFT - SERIES (2) Y4PC834 - SERIES (2)								

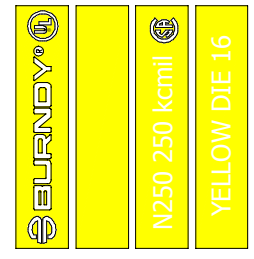

BARREL MARKING

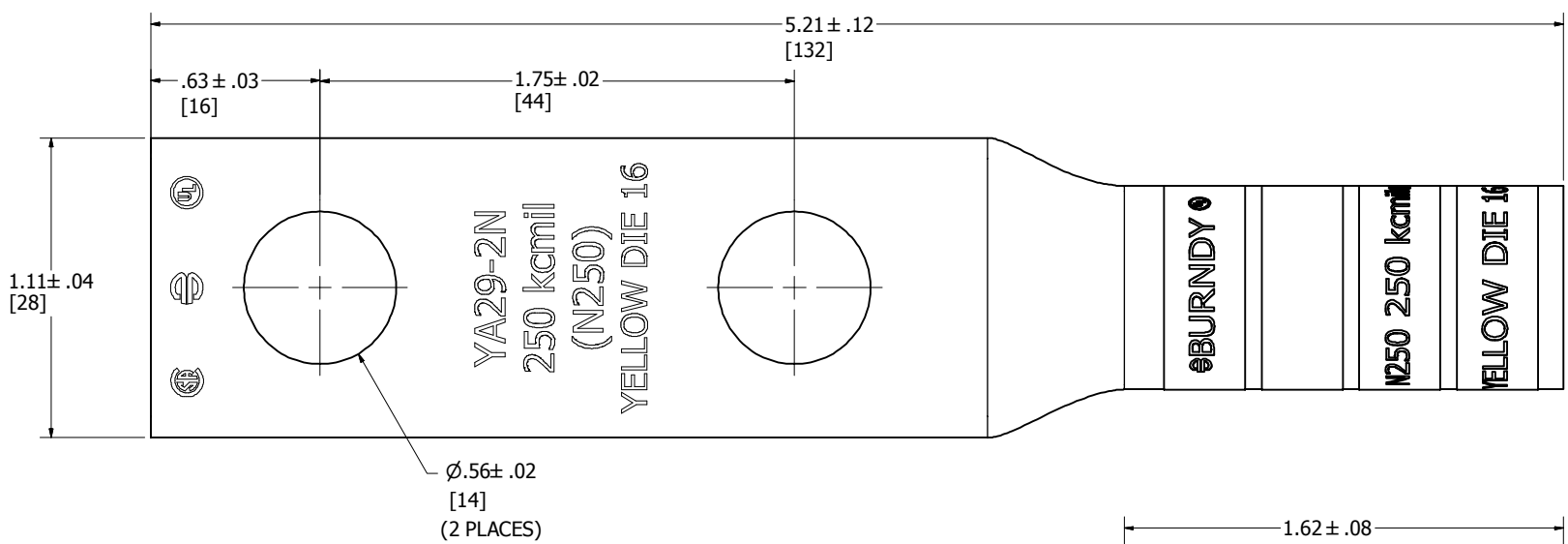
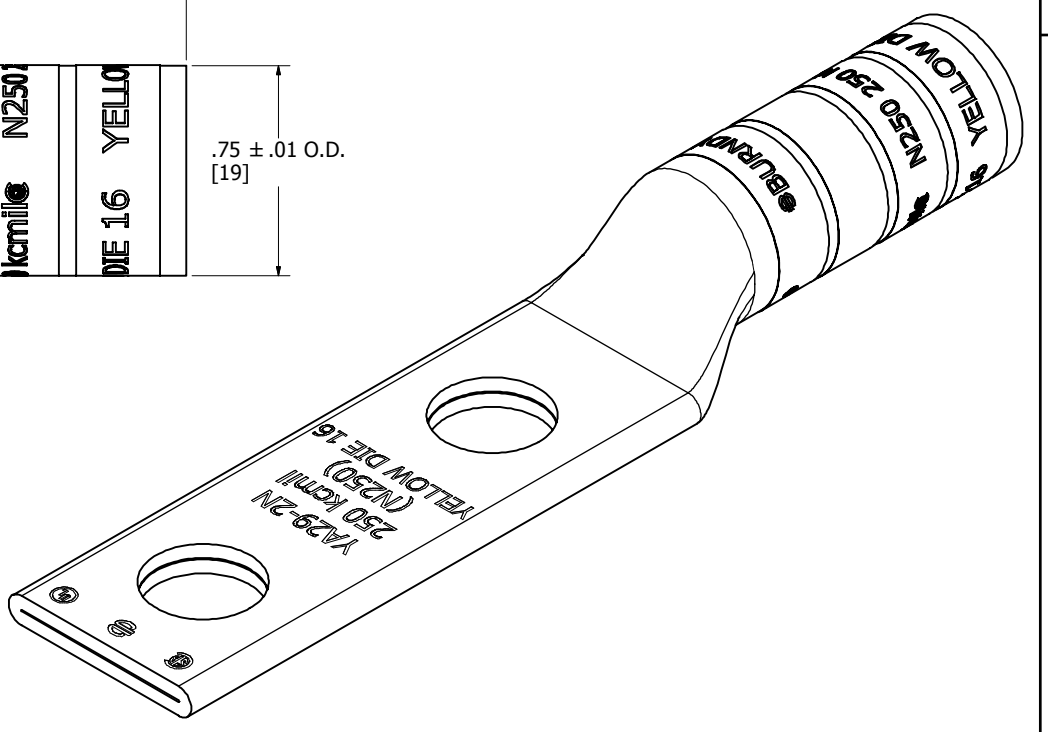
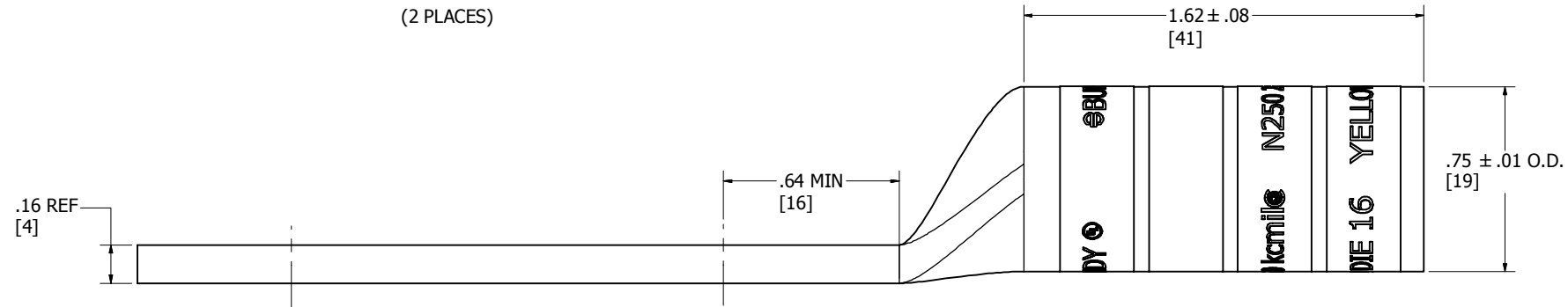

NOTES:

- MATERIAL: COPPER TUBING
- FINISH: TIN PLATED.
- CATALOG # PT6515 ADAPTOR IS REQUIRED TO USE "U" DIES IN Y45 SERIES TOOLS.
- CATALOG # PUADP-1 ADAPTOR IS REQUIRED TO USE "U" DIES IN Y46 SERIES TOOLS.
- Y35P3 INDENTOR ADAPTOR REQUIRED FOR Y34PR INDENTOR.
- PERMANENT DIE IN TOOLING.
- DIMENSIONS IN BRACKETS [] ARE IN MILLIMETERS ROUNDED OFF TO THE NEAREST MILLIMETER, UNLESS OTHERWISE NOTED, AND ARE FOR REFERENCE ONLY.
- FOR USE BY CUSTOMERS THAT HAVE THIS HYPRESS™ NO NEW Y34A HYPRESS™ TOOLS ARE BEING PROCESSED. Y34A USES A--D TYPE NEST DIES.
- UL LISTED AND CSA CERTIFIED WIRE CONNECTOR.
- "X", "W-RT", "W-VT", "U", & "L" DIE SETS ARE COLOR CODED. "A", "B", AND "C" DIES ARE NOT COLOR CODED. NESTS AND INDENTOR TYPE ARE NOT COLOR CODED.

TO ORDER BURNDY® PRODUCTS CALL		HYLUG™															
UNITED STATES 1-800-346-4175 (LONDONDERRY, NH)		ITEM NO: 502430															
CANADA: 1-800-361-6975 (QUEBEC) 1-800-387-6487 (ALL OTHER PROVINCES)		CAT. NO: YA292N															
FOR PRODUCT INFO: http://www.burndy.com		<table border="1"> <tr> <td>DRAWN BY: S.SRIRAM</td> <td>11/7/2012</td> </tr> <tr> <td>CHECKER: J. MICHAUD</td> <td>4/9/2013</td> </tr> <tr> <td>DSN APRVL: R. ROMAN</td> <td>3/1/2013</td> </tr> <tr> <td>MFG APRVL: M. KNAPTON</td> <td>2/28/2013</td> </tr> <tr> <td>QA APRVL: T. WATTS</td> <td>2/28/2013</td> </tr> <tr> <td>MKT APRVL: J. SYLVIA</td> <td>3/19/2013</td> </tr> </table>		DRAWN BY: S.SRIRAM	11/7/2012	CHECKER: J. MICHAUD	4/9/2013	DSN APRVL: R. ROMAN	3/1/2013	MFG APRVL: M. KNAPTON	2/28/2013	QA APRVL: T. WATTS	2/28/2013	MKT APRVL: J. SYLVIA	3/19/2013		
DRAWN BY: S.SRIRAM	11/7/2012																
CHECKER: J. MICHAUD	4/9/2013																
DSN APRVL: R. ROMAN	3/1/2013																
MFG APRVL: M. KNAPTON	2/28/2013																
QA APRVL: T. WATTS	2/28/2013																
MKT APRVL: J. SYLVIA	3/19/2013																
<table border="1"> <tr> <td>PROD FAM: CM&R COMPRESSION</td> <td>DRAWING NO</td> <td>REV</td> </tr> <tr> <td>PROJECT #: --</td> <td>50013984</td> <td>A</td> </tr> <tr> <td>DOCUMENT TYPE: SALES</td> <td>SIZE</td> <td></td> </tr> <tr> <td>REL LEVEL: Released</td> <td>D</td> <td></td> </tr> </table>		PROD FAM: CM&R COMPRESSION	DRAWING NO	REV	PROJECT #: --	50013984	A	DOCUMENT TYPE: SALES	SIZE		REL LEVEL: Released	D		<table border="1"> <tr> <td colspan="2">SHEET 1 OF 1</td> </tr> </table>		SHEET 1 OF 1	
PROD FAM: CM&R COMPRESSION	DRAWING NO	REV															
PROJECT #: --	50013984	A															
DOCUMENT TYPE: SALES	SIZE																
REL LEVEL: Released	D																
SHEET 1 OF 1																	